

EXCEPT AS MAY BE OTHERWISE PROVIDED BY CONTRACT, THESE DRAWINGS AND SPECIFICATIONS ARE THE PROPERTY OF AUTOMATED PROCESSES, INC., AND ARE ISSUED IN STRICT CONFIDENCE AND SHALL NOT BE REPRODUCED OR COPIED, OR USED AS THE BASIS FOR THE MANUFACTURE OR SALE OF APPARATUS WITHOUT PERMISSION.

REVISION HISTORY				
ZONE	REV	DESCRIPTION	DATE	APPROVED
	-	RELEASE	5/11/2018	JKR
	-	UPDATE MODEL. ADD CALLOUT FOR UPDATED AREA(S). ADD OVERALL DIMENSIONS.	8/6/2018	JKR

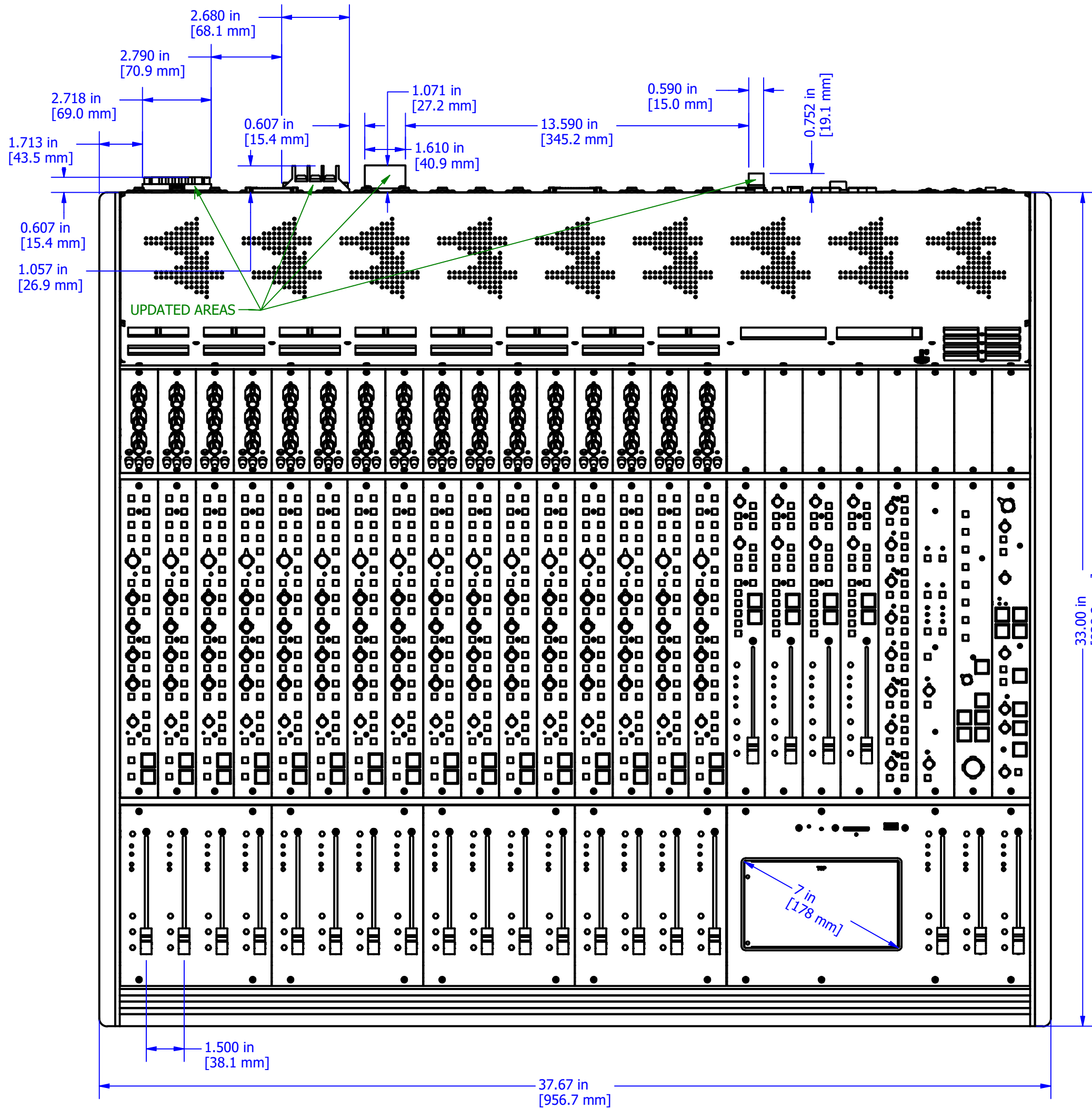

**TOP VIEW**  
SCALE 1 / 4

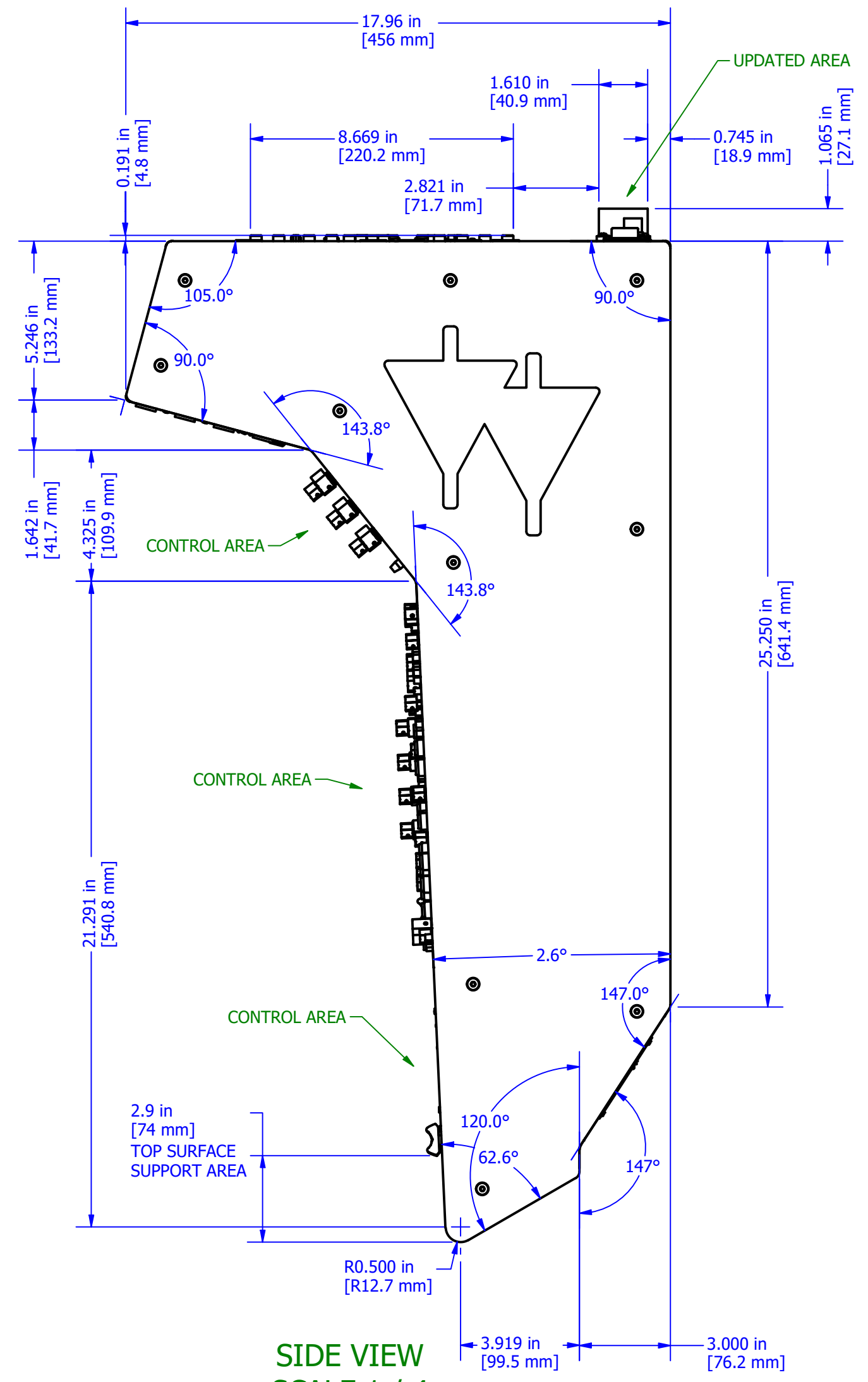

**SIDE VIEW**  
SCALE 1 / 4

**WEIGHT**  
STANDARD FRAME: 230 LBS  
EXPANSION FRAME: 165 LBS  
32 CHANNEL FRAME: 390 LBS

**ROAD CASE PART NUMBERS**  
STANDARD FRAME: 853-0015  
EXPANSION FRAME: 853-0014

**SHIPPING CRATE PART NUMBERS**  
STANDARD FRAME: 853-0015  
EXPANSION FRAME: 853-0016  
32 CHANNEL FRAME: 853-0017  
48 CHANNEL FRAME: 853-0018

**PLEASE OBSERVE REAR SUPPORT CONNECTOR CUTOUTS**  
**ENSURE THAT TRANSPORT CASES/CRATES DO NOT CONTACT THE LABELED CONTROL AREAS**

<small>TOLERANCES UNLESS OTHERWISE NOTED</small> <small>FRACTIONS: +/-</small> <small>XX = +/- 0.02</small> <small>XXX = +/- 0.005</small> <small>ANGLES = +/- 1/2</small> <input type="checkbox"/> SEE SEPARATE PARTS LIST	<small>DRAWN</small> jncards <small>DATE</small> 5/11/2018	<b>AUTOMATED PROCESSES, INC.</b> <small>8301 PATUXENT RANGE ROAD, JESSUP, MD 20794 301 776 7879</small>	<b>TITLE</b> 1608-II DIMENSIONS				
	<small>CHECK</small> DATE				<small>APPVD</small> DATE		
	<small>MATERIAL</small>		<small>FINISH</small>	<small>SIZE</small> C	<small>DWG NO.</small> 42-999-1530	<small>REV</small> -	<small>SHEET</small> 1 OF 2

EXCEPT AS MAY BE OTHERWISE PROVIDED BY CONTRACT, THESE DRAWINGS AND SPECIFICATIONS ARE THE PROPERTY OF AUTOMATED PROCESSES, INC., AND ARE ISSUED IN STRICT CONFIDENCE AND SHALL NOT BE REPRODUCED OR COPIED, OR USED AS THE BASIS FOR THE MANUFACTURE OR SALE OF APPARATUS WITHOUT PERMISSION.

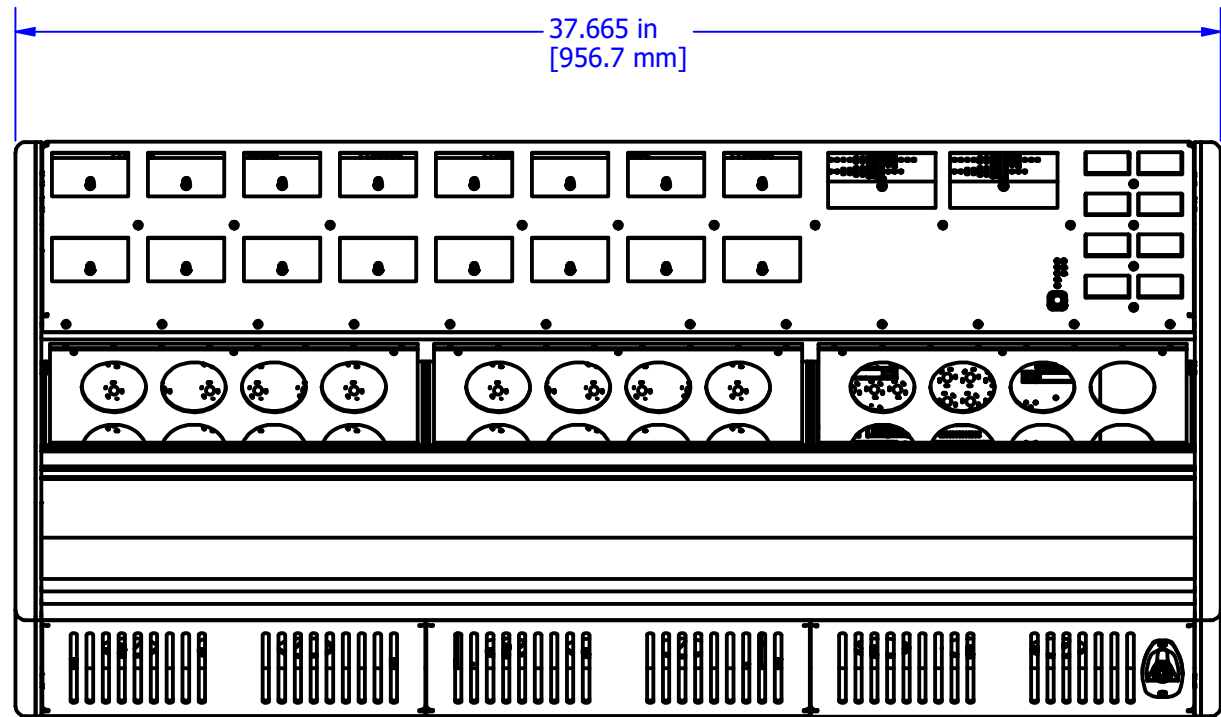

921-0530  
STANDARD 16-CHANNEL FRAME

WEIGHT: 230 LBS  
POWER SUPPLIES: 1  
POWER DRAW\*: 250 Watts / 853 BTU/hr  
290 Watts / 990 BTU/hr Automated

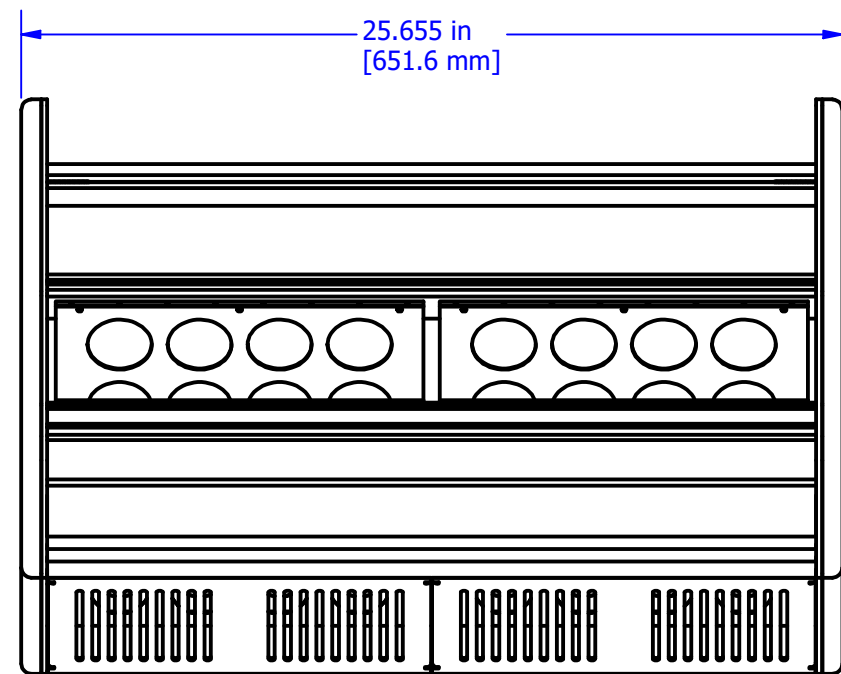

921-0531  
16-CHANNEL EXPANDER FRAME

WEIGHT: 165 LBS  
POWER SUPPLIES: 1  
POWER DRAW\*: 200 Watts / 682 BTU/hr  
220 Watts / 750 BTU/hr Automated

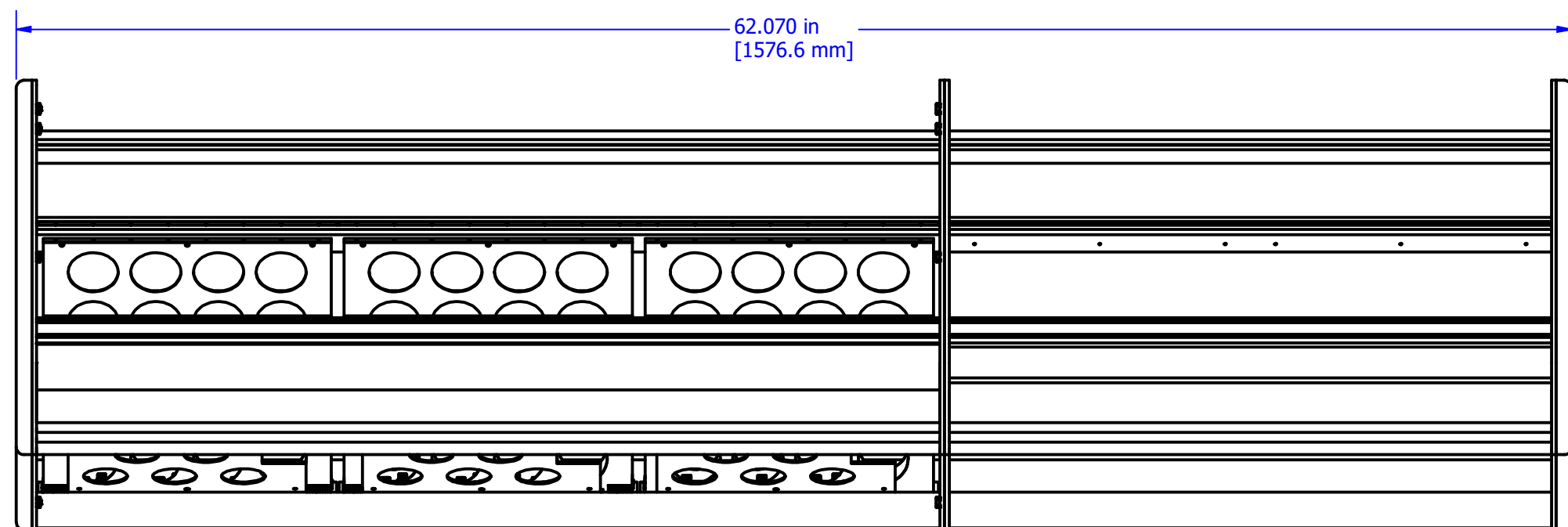

921-0532  
32-CHANNEL BOLT TOGETHER FRAME

\* POWER DRAW GIVEN WITH STANDARD 500 EQ LOAD  
POWER WILL CHANGE AS EQS ARE ADD, REMOVED, OR CHANGED

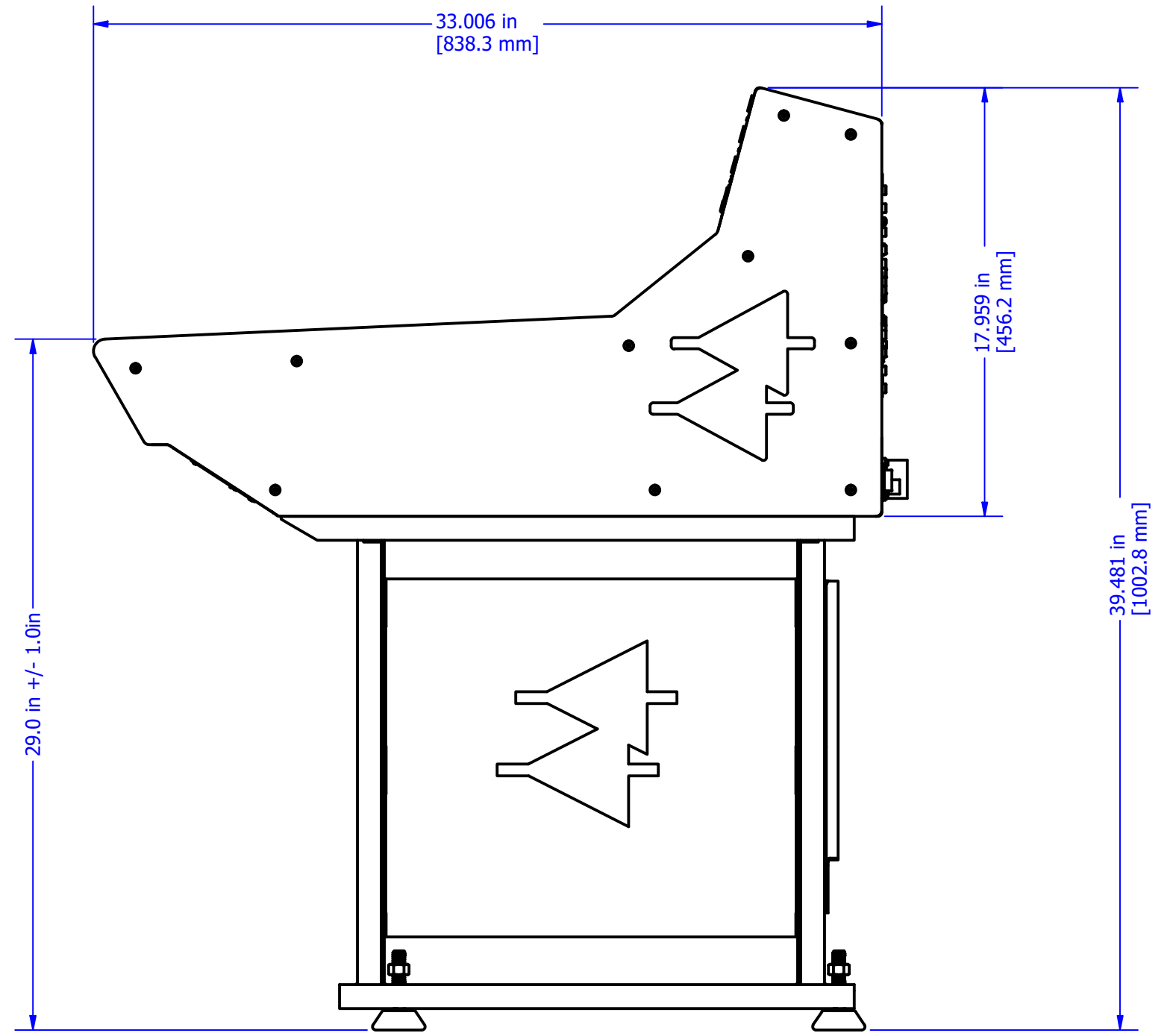

WEIGHT: 390 LBS  
POWER SUPPLIES: 2  
POWER DRAW\*: 450 Watts / 1535 BTU/hr  
510 Watts / 1740 BTU/hr Automated  
Load Split 55% Main, 45% Expander

TOLERANCES UNLESS OTHERWISE NOTED FRACTIONS: +/- .XX = +/- 0.02 .XXX = +/- 0.005 ANGLES = +/- 1/2	DRAWN jnchards DATE 5/10/2018	<b>AUTOMATED PROCESSES, INC.</b> 8301 PATUXENT RANGE ROAD, JESSUP, MD 20794 301 776 7879	TITLE 1608-II DIMENSIONS		
	CHECK DATE		SIZE C	DWG NO. 42-999-1530	REV -
SEE SEPARATE PARTS LIST	APPVD DATE	MATERIAL	FINISH		

A

B

C

D

EXCEPT AS MAY BE OTHERWISE PROVIDED BY CONTRACT, THESE DRAWINGS AND SPECIFICATIONS ARE THE PROPERTY OF AUTOMATED PROCESSES, INC., AND ARE ISSUED IN STRICT CONFIDENCE AND SHALL NOT BE REPRODUCED OR COPIED, OR USED AS THE BASIS FOR THE MANUFACTURE OR SALE OF APPARATUS WITHOUT PERMISSION.

FRONT  
SCALE 1 / 3

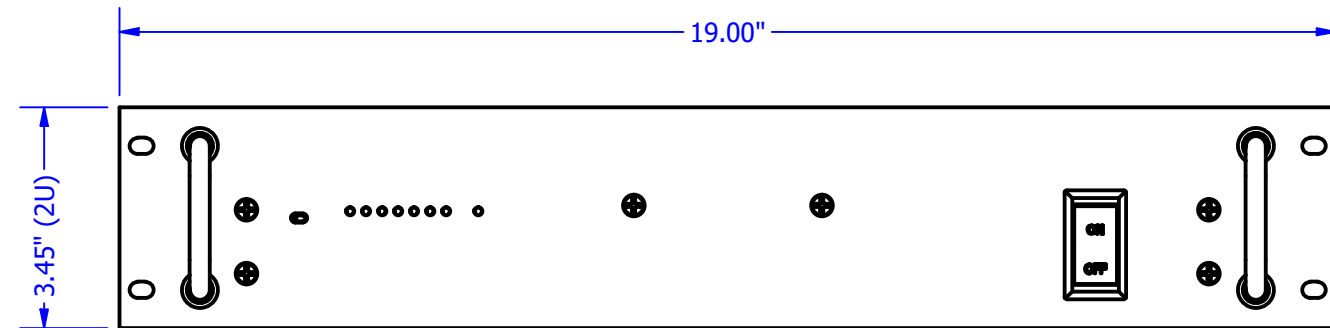

SIDE  
SCALE 1 / 3

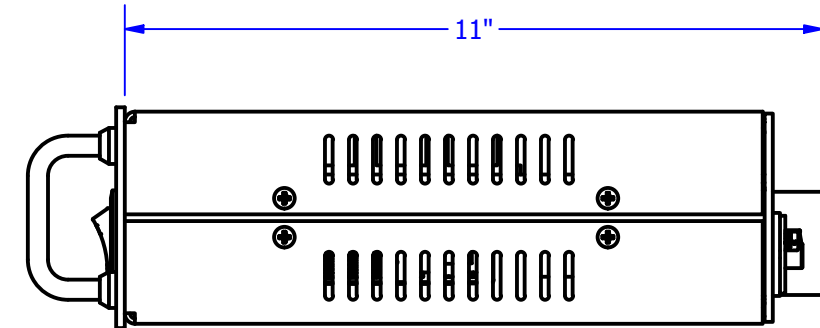

MUST ALLOW ADDITIONAL DEPTH FOR POWER CABLE EXIT

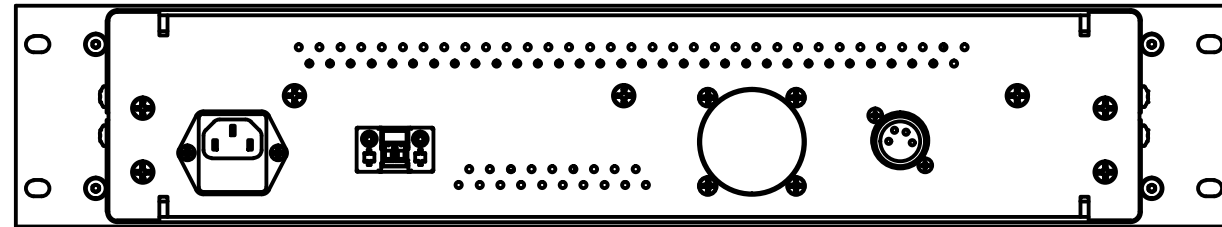

WEIGHT: 15lbs (6.8kg)

PLEASE INSTALL INTO RACK WITH AT LEAST 1U BLANK SPACE ABOVE FOR COOLING.

TOLERANCES UNLESS OTHERWISE NOTED FRACTIONS: +/- .XX = +/- 0.02 .XXX = +/- 0.005 ANGLES = +/- 1/2° <input type="checkbox"/> SEE SEPARATE PARTS LIST	DRAWN jrichards DATE 3/28/2019	 <b>AUTOMATED PROCESSES, INC.</b> 8301 PATUXENT RANGE ROAD, JESSUP, MD 20794 301 776 7879			
	CHECK DATE				
	APPVD DATE	TITLE 1608-11 / 2448 POWER SUPPLY DIMENSIONS			
	MATERIAL				
<input type="checkbox"/> SEE SEPARATE PARTS LIST	FINISH	SIZE B	DWG NO. 42-951-0972 DIM	REV A1	SHEET 1 OF 1