

EXCEPT AS MAY BE OTHERWISE PROVIDED BY CONTRACT, THESE DRAWINGS AND SPECIFICATIONS ARE THE PROPERTY OF AUTOMATED PROCESSES, INC., AND ARE ISSUED IN STRICT CONFIDENCE AND SHALL NOT BE REPRODUCED OR COPIED, OR USED AS THE BASIS FOR THE MANUFACTURE OR SALE OF APPARATUS WITHOUT PERMISSION.

REVISION HISTORY				
ZONE	REV	DESCRIPTION	DATE	APPROVED
	A	UPDATE MODEL. ADD OVERALL DIMENSIONS.	8/6/2018	JKR
	A	CORRECTED OVERALL WIDTH FROM 49.925 TO 49.675	8/16/2018	TPH

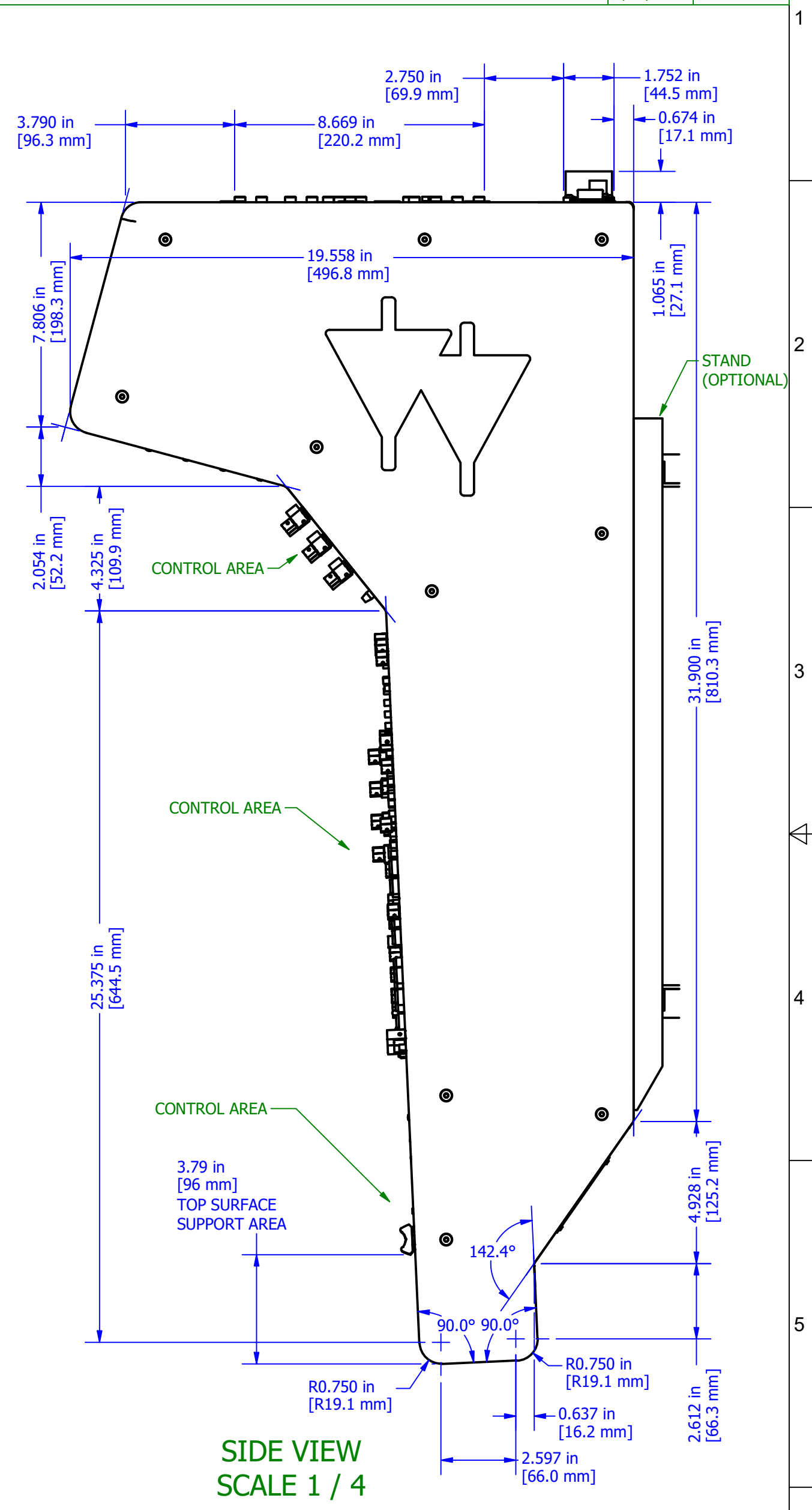
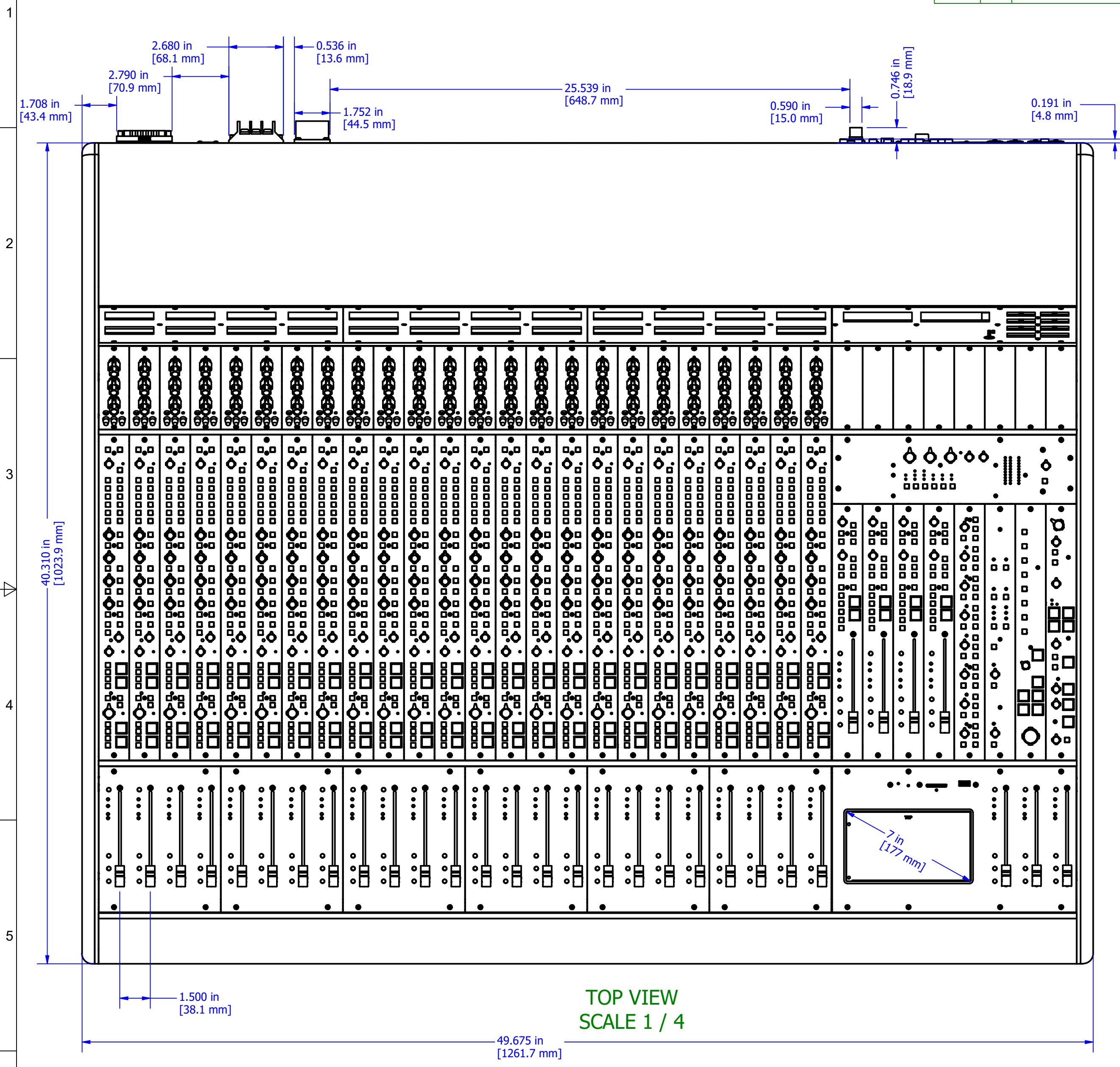

WEIGHT
STANDARD FRAME: 350 LBS

ROAD CASE PART NUMBERS
STANDARD FRAME: 853-0023
EXPANSION FRAME: 853-0024

SHIPPING CRATE PART NUMBERS
STANDARD FRAME: 853-0025
EXPANSION FRAME: 853-0026

PLEASE OBSERVE REAR SUPPORT CONNECTOR CUTOUTS
ENSURE THAT TRANSPORT CASES/CRATES DO NOT CONTACT THE LABELED CONTROL AREAS

TOLERANCES UNLESS OTHERWISE NOTED	DRAWN jncards DATE 5/11/2018	<p>AUTOMATED PROCESSES, INC. 8301 PATUXENT RANGE ROAD, JESSUP, MD 20794 301 776 7879</p>	TITLE 2448 DIMENSIONS		
FRACTIONS: +/-	CHECK DATE		SIZE C	DWG NO. 42-999-1534	REV A
XX = +/- 0.02	APPVD DATE		SHEET 1 OF 3		
XXX = +/- 0.005	MATERIAL				
ANGLES = +/- 1/2°	FINISH				
<input type="checkbox"/> SEE SEPARATE PARTS LIST					

EXCEPT AS MAY BE OTHERWISE PROVIDED BY CONTRACT, THESE DRAWINGS AND SPECIFICATIONS ARE THE PROPERTY OF AUTOMATED PROCESSES, INC., AND ARE ISSUED IN STRICT CONFIDENCE AND SHALL NOT BE REPRODUCED OR COPIED, OR USED AS THE BASIS FOR THE MANUFACTURE OR SALE OF APPARATUS WITHOUT PERMISSION.

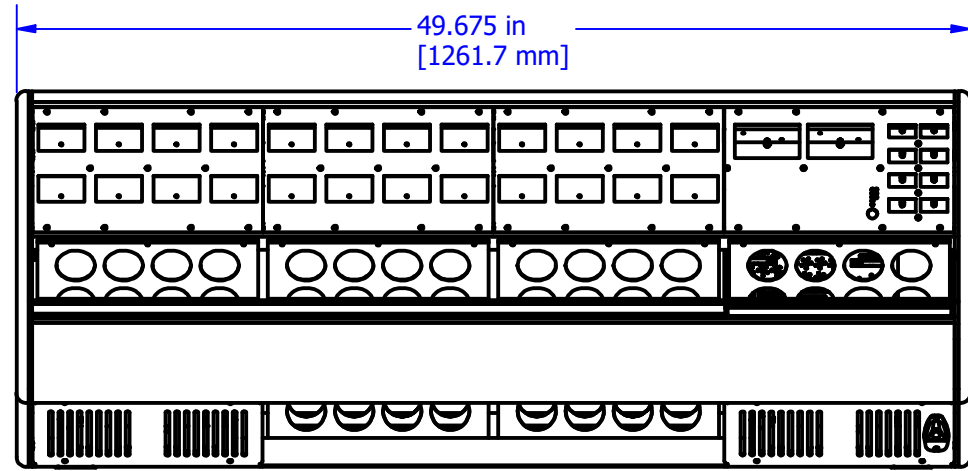

921-0534
STANDARD 24-CHANNEL FRAME

WEIGHT: 350 LBS
POWER SUPPLIES: 1
POWER DRAW*: 400 Watts / 1365 BTU/hr
450 Watts / 1535 BTU/hr Automated

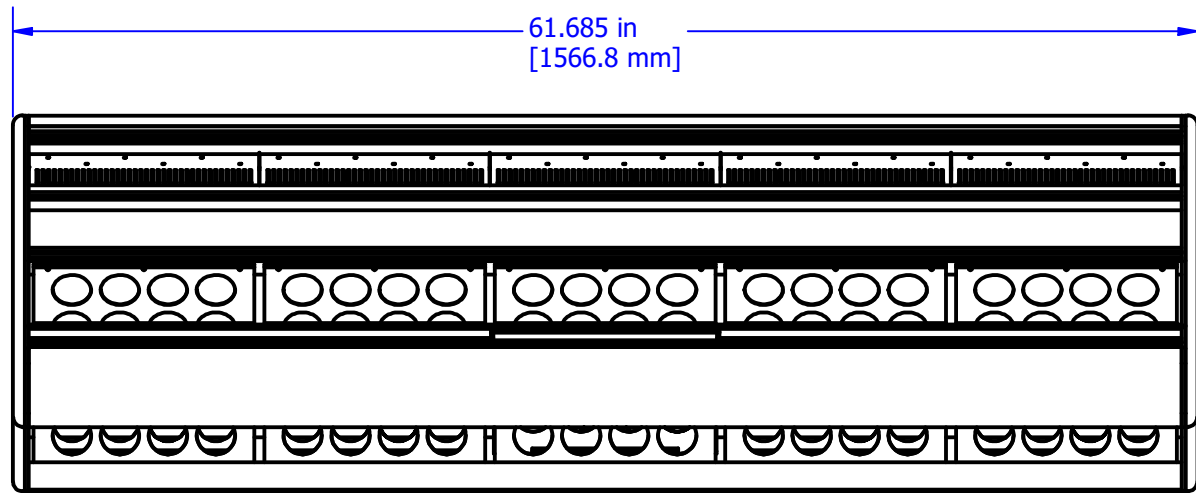

921-0535
32-CHANNEL SINGLE FRAME, 1-16, MASTER, 17-32

WEIGHT: 425 LBS
POWER SUPPLIES: 2
POWER DRAW*: 475 Watts / 1620 BTU/hr
550 Watts / 1877 BTU/hr Automated
Load Split 55% Main, 45% Expander

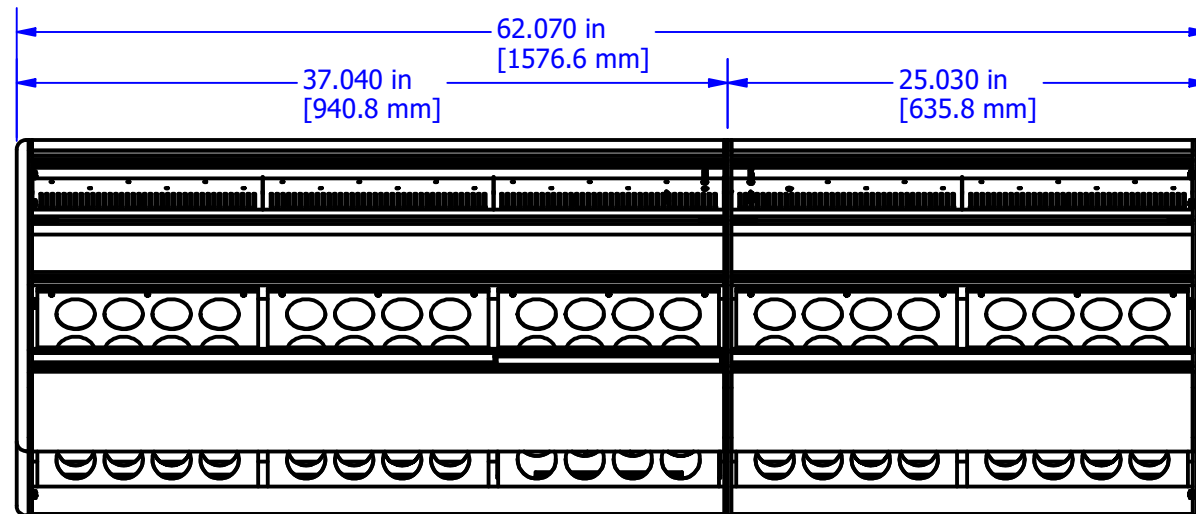

921-0537
32-CHANNEL SPLIT FRAME, 1-16, MASTER, 17-32

WEIGHT: 430 LBS
POWER SUPPLIES: 2
POWER DRAW*: 475 Watts / 1620 BTU/hr
550 Watts / 1877 BTU/hr Automated
Load Split 55% Main, 45% Expander

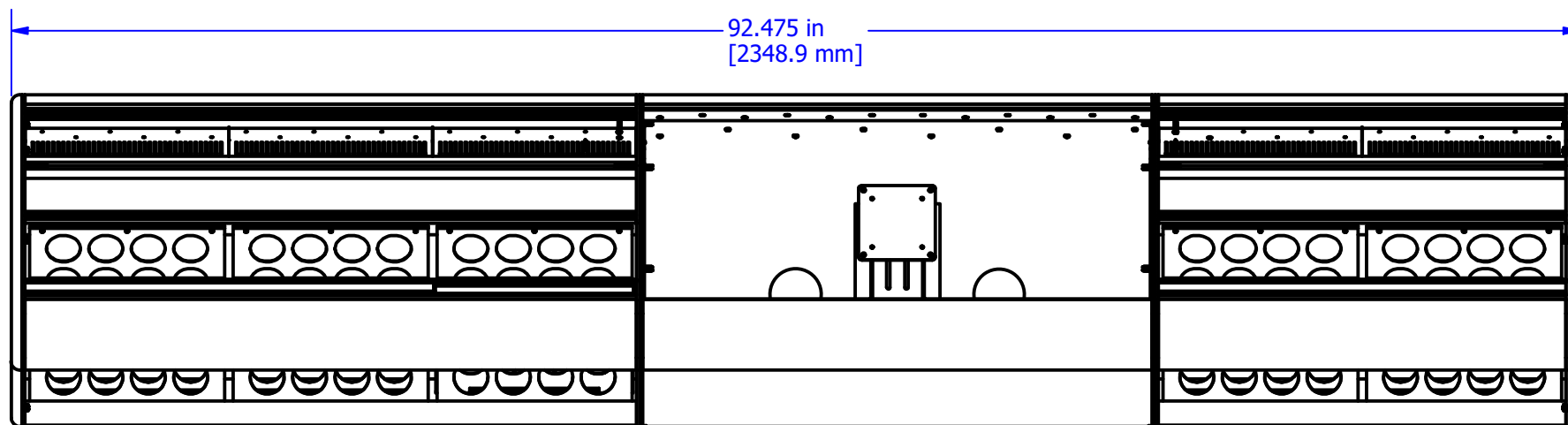

921-0536
32-CHANNEL w/ 30" DAW BUCKET FRAME
ORDER CAN BE 1-16, MASTER, DAW, 17-32 or 1-16, DAW, MASTER, 17-32

* POWER DRAW GIVEN WITH STANDARD 500 EQ LOAD
POWER WILL CHANGE AS EQS ARE ADD, REMOVED, OR CHANGED

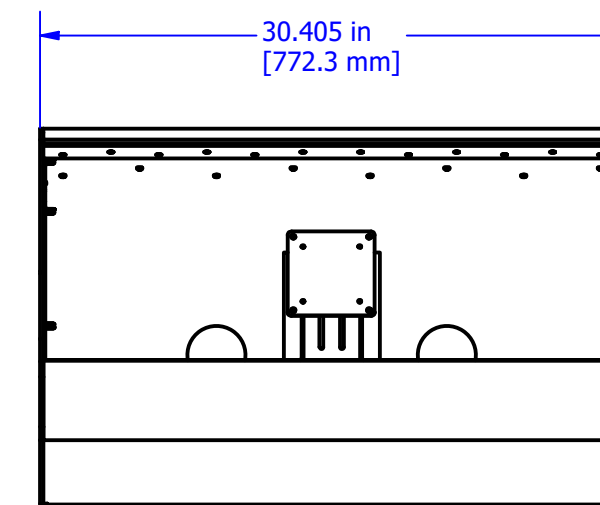
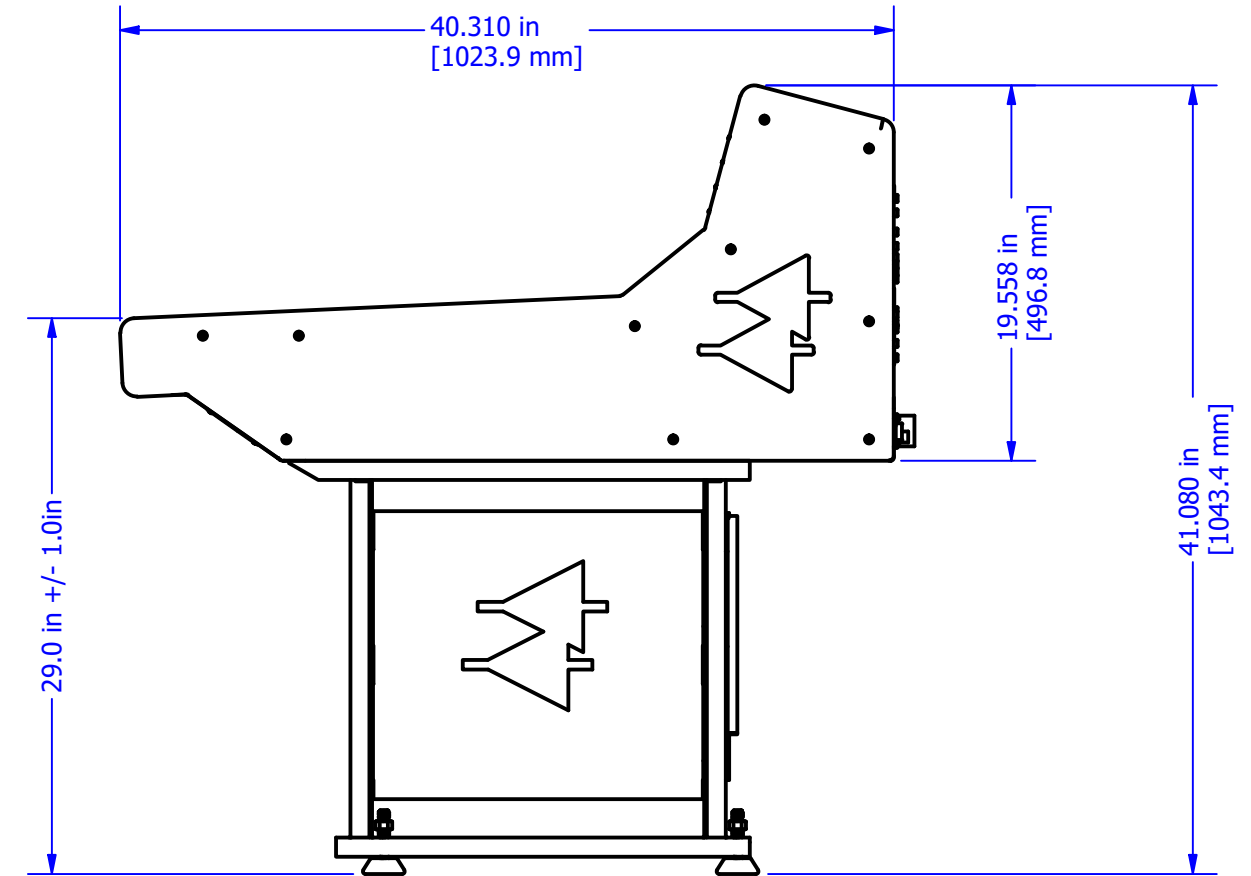

30 in DAW BUCKET, 921-0529 FOR AVID S3 or 921-0528 FOR WORK SURFACE
CAN BE ADDED TO THE END OF ANY FRAME
or IN THE 32 CHANNEL FRAME AS SHOWN IN 921-0536

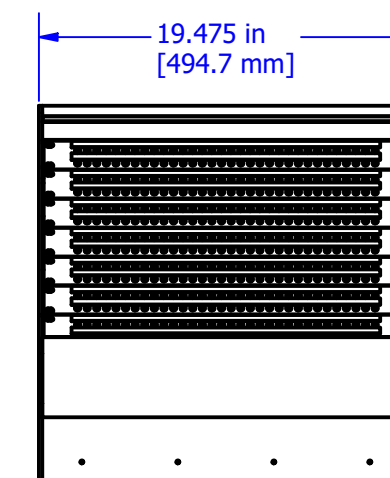

921-0527
19 in RACK SPACE BUCKET WITH 8U OF SPACE FOR PATCH BAY
CAN BE ADDED TO THE END OF ANY FRAME

WEIGHT: 530 LBS
POWER SUPPLIES: 2
POWER DRAW*: 475 Watts / 1620 BTU/hr
550 Watts / 1877 BTU/hr Automated
Load Split 55% Main, 45% Expander

TOLERANCES UNLESS OTHERWISE NOTED FRACTIONS: +/- .XX = +/- 0.02 .XXX = +/- 0.005 ANGLES = +/- 1/2° <input type="checkbox"/> SEE SEPARATE PARTS LIST	DRAWN: jnchards DATE: 5/11/2018	AUTOMATED PROCESSES, INC. 8301 PATUXENT RANGE ROAD, JESSUP, MD 20794 301 776 7879	TITLE: 2448 DIMENSIONS			
	CHECK: DATE					
	APPVD: DATE		SIZE: C	DWG NO.: 42-999-1534	REV: A	SHEET: 2 of 3
	MATERIAL					

EXCEPT AS MAY BE OTHERWISE PROVIDED BY CONTRACT, THESE DRAWINGS AND SPECIFICATIONS ARE THE PROPERTY OF AUTOMATED PROCESSES, INC., AND ARE ISSUED IN STRICT CONFIDENCE AND SHALL NOT BE REPRODUCED OR COPIED, OR USED AS THE BASIS FOR THE MANUFACTURE OR SALE OF APPARATUS WITHOUT PERMISSION.

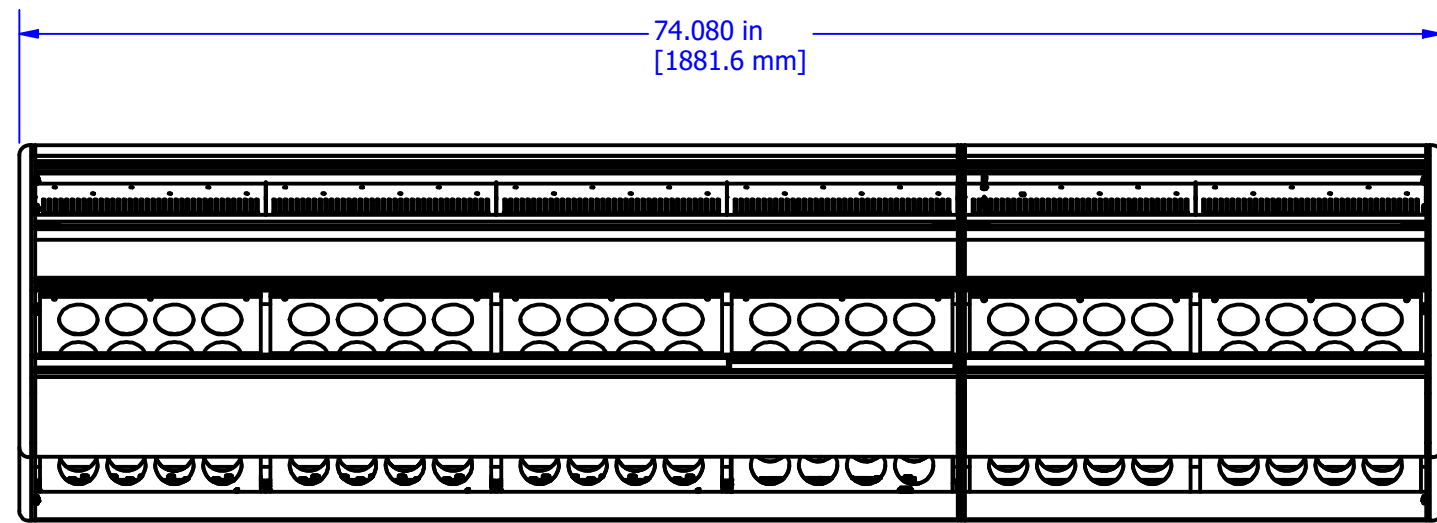

921-0538
40-CHANNEL SPLIT FRAME, 1-24, MASTER, 17-32

WEIGHT: 510 LBS
POWER SUPPLIES: 2
POWER DRAW*: 550 Watts / 1877 BTU/hr
650 Watts / 2218 BTU/hr Automated
Load Split 60% Main, 40% Expander

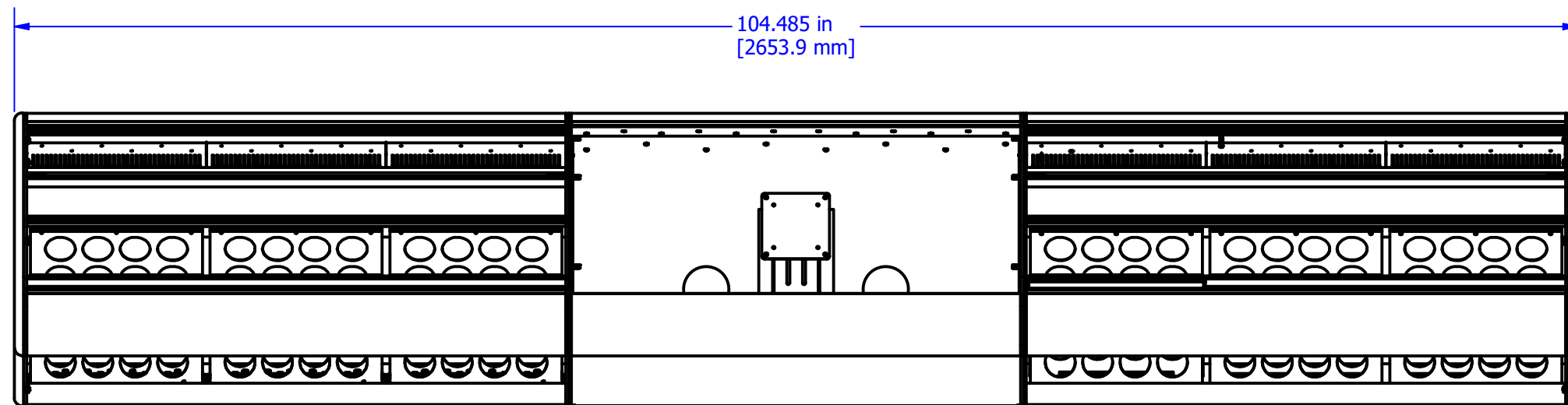

921-0539
40-CHANNEL w/ 30" DAW BUCKET FRAME
ORDER CAN BE 1-24, MASTER, DAW, 25-40 or 1-24, DAW, MASTER, 25-40

WEIGHT: 550 LBS
POWER SUPPLIES: 2
POWER DRAW*: 550 Watts / 1877 BTU/hr
650 Watts / 2218 BTU/hr Automated
Load Split 60% Main, 40% Expander

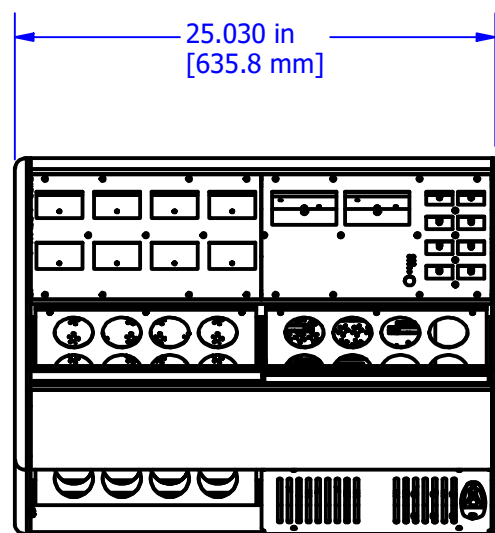

921-0540
24-CHANNEL SPLIT FRAME, 1-8, MASTER, 9-24

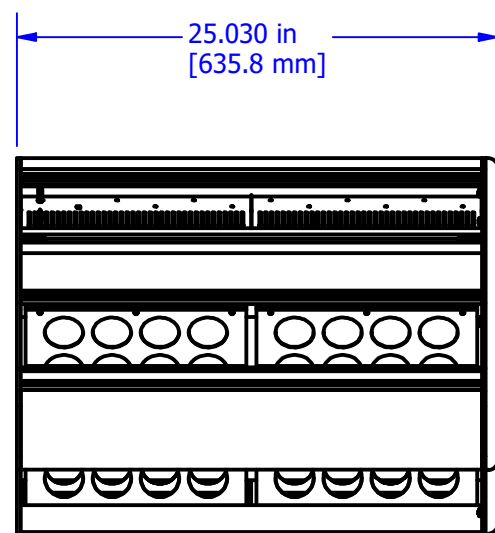

WEIGHT: 350 LBS
POWER SUPPLIES: 1
POWER DRAW*: 400 Watts / 1365 BTU/hr
450 Watts / 1535 BTU/hr Automated

* POWER DRAW GIVEN WITH STANDARD 500 EQ LOAD
POWER WILL CHANGE AS EQs ARE ADD, REMOVED, OR CHANGED

TOLERANCES UNLESS OTHERWISE NOTED
FRACTIONS: +/-
.XX = +/- 0.02
.XXX = +/- 0.005
ANGLES = +/- 1/2°

SEE SEPARATE PARTS LIST

DRAWN jnchards	DATE 5/11/2018
CHECK	DATE
APPVD	DATE
MATERIAL	
FINISH	

AUTOMATED PROCESSES, INC. 8301 PATUXENT RANGE ROAD, JESSUP, MD 20794 301 776 7879		TITLE 2448 DIMENSIONS	
		SIZE C	DWG NO. 42-999-1534

A

B

C

D

EXCEPT AS MAY BE OTHERWISE PROVIDED BY CONTRACT, THESE DRAWINGS AND SPECIFICATIONS ARE THE PROPERTY OF AUTOMATED PROCESSES, INC., AND ARE ISSUED IN STRICT CONFIDENCE AND SHALL NOT BE REPRODUCED OR COPIED, OR USED AS THE BASIS FOR THE MANUFACTURE OR SALE OF APPARATUS WITHOUT PERMISSION.

FRONT
SCALE 1 / 3

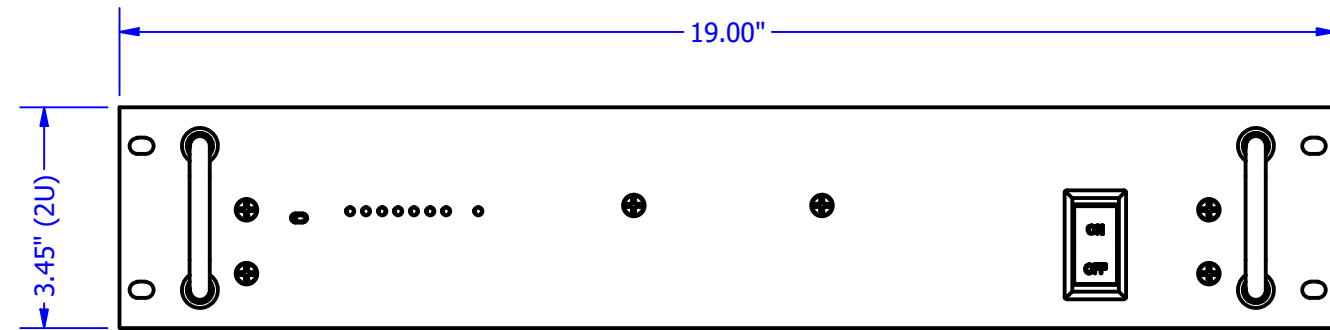

SIDE
SCALE 1 / 3

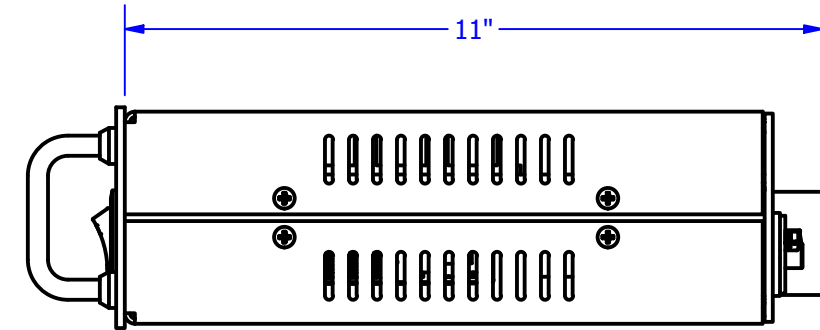

MUST ALLOW ADDITIONAL DEPTH FOR POWER CABLE EXIT

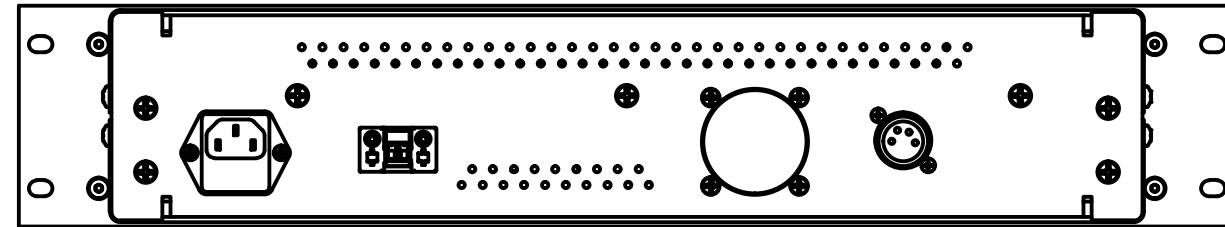

WEIGHT: 15lbs (6.8kg)

PLEASE INSTALL INTO RACK WITH AT LEAST 1U BLANK SPACE ABOVE FOR COOLING.

TOLERANCES UNLESS OTHERWISE NOTED FRACTIONS: +/- .XX = +/- 0.02 .XXX = +/- 0.005 ANGLES = +/- 1/2° <input type="checkbox"/> SEE SEPARATE PARTS LIST	DRAWN jrichards DATE 3/28/2019	AUTOMATED PROCESSES, INC. 8301 PATUXENT RANGE ROAD, JESSUP, MD 20794 301 776 7879			
	CHECK DATE				
	APPVD DATE	TITLE 1608-11 / 2448 POWER SUPPLY DIMENSIONS			
	MATERIAL				
<input type="checkbox"/> SEE SEPARATE PARTS LIST	FINISH	SIZE B	DWG NO. 42-951-0972 DIM	REV A1	SHEET 1 OF 1