



3124MV DISCRETE 4-CHANNEL MIC/LINE PRE-AMP w/MIXER USER GUIDE

The API 3124MV is a compact, high-quality 4-channel preamplifier with an added stereo mixer. It features the same high-quality preamps available in all API consoles with added stereo pan and aux send functionality. These stereo pans and aux sends are bussed to master output controls and then to the rear panel jacks. Additionally, a stereo return is provided to return effects or cascade additional mixers for more inputs. The stereo aux return control acts to balance the left/right signal while staying stereo, but can also be used as a mono return. The 3124MV exhibits the same reliability, long life, and uniformity that is characteristic of all other API products.



FEATURES:

1. Front panel Hi-Z 1/4 inch (line/instrument) input, rear panel XLR (mic) input and output
2. Variable input level control knob (feeds to mix bus)
3. Gain control: Mic preamp with gain range +34 dB to +65 dB, line/instrument preamp with gain range +14 dB to +45 dB
4. LED VU meter for monitoring input level
5. Polarity switch inverts polarity of mic input signal
6. 48V phantom switchable power
7. Pad switch (applies to XLR [mic] and Hi-Z 1/4 inch [line/instrument]) reduces input signal by 20 dB
8. Switchable input selector: when engaged - rear XLR (mic) input active, when disengaged - front panel Hi-Z 1/4 inch (instrument/line) input active
9. 3:1 output transformer tap selector (channel output only - does not affect mix level): when engaged - reduces output gain ratio from 1:3 to 1:1 (appx. 10 dB), when disengaged - output gain ratio 1:3
10. Left/right pan control adjusts input's stereo placement on master bus
11. Aux send control adjusts amount of input signal sent to auxiliary bus
12. Master bus stereo controls adjust levels in left and right stereo space
13. Aux bus output level control
14. Stereo aux return control adjusts left/right signal while staying stereo (can also be used as a mono return)

The API 3124MV also comes with API's unique Five Year Warranty.

BLOCK DIAGRAM

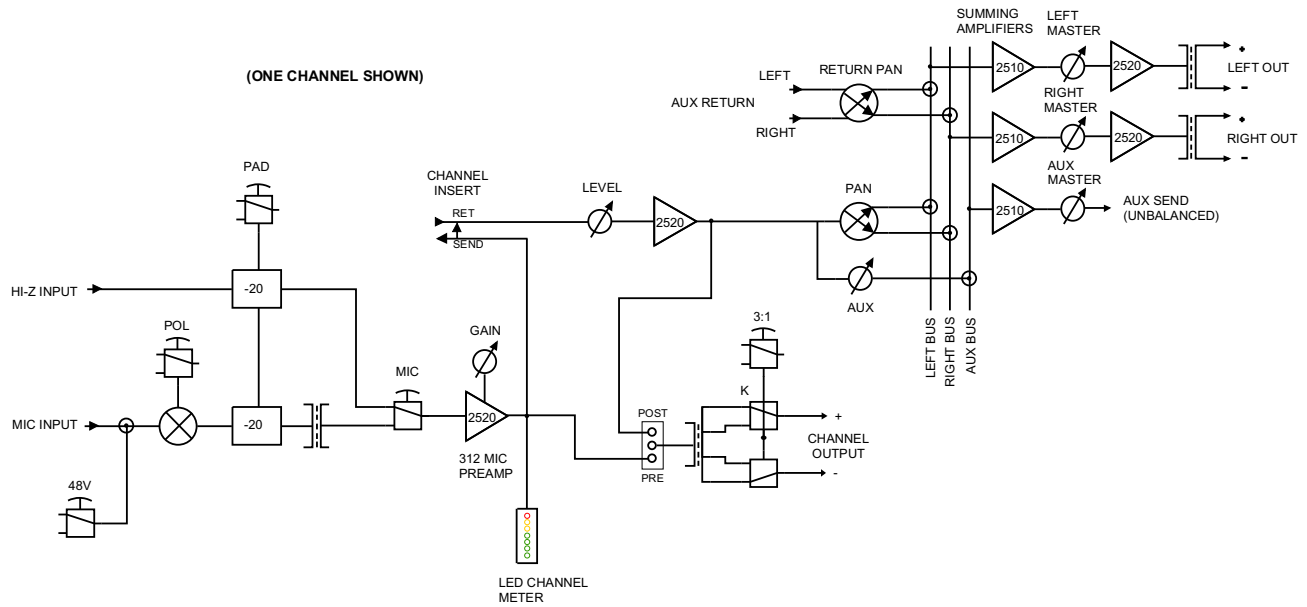

Specifications

Input Impedance:	Mic: 1500 Ohms Hi-Z: 470 kOhms un-balanced
Output Impedance:	Less than 75 Ohms on channel outputs
Nominal Levels:	XLR channel output: +4 dBu
Frequency Response:	+0, -0.5, 10 Hz to 20 kHz (-0.5 at 10 Hz)
Noise EIN:	Mic: -129 Hi-Z actual: -125
Distortion:	All outputs at +4 dBu out, 0.03% at +22 dBu, 0.09% Max
Gain Range:	150 Ohms input 10 dB Min., 65 dB Max (inc. PAD). Unbal. input 14 dB Min., 50 dB Max
VU Meter:	Calibrated for XLR outputs, OVU = +4 dBu
Controls:	GAIN, PAD (20 dB), 48 Volts, POL (polarity), MIC (mic/un-bal), VU, AC
Power Consumption, Quiescent:	19.2 Watts
Size:	19" X 1.75" (1U) X 11" deep
Size (Boxed for Shipping):	23.25" X 6.5" X 16.5"
Actual Weight:	11.54 lbs.
Shipping Weight:	15.3 lbs.